

PBOX®
www.pboxlighting.com



X5 & X5 PLUS

Solar Street Light

User Manual

Powerband Green Energy Ltd

3/F, No.1 Workshop, No.15, Pingbei 2nd Road, Nanping, Zhuhai,
Guangdong, P.R. China 519060.

Tel: 86-756-8680199 Fax: 86-756-8682090

Email: sales@pboxlighting.com

Thank you for choosing the PBOX X5 series solar street light.
For any questions, please email us at sales@pboxlighting.com.

Please refer to the actual products if the provided diagrams show slight differences.



Precaution	2
X5 All-In-One / X5 Split Type	
Parts Description	3
Components List	4
X5 Plus All-In-One / X5 Plus Split Type	
Parts Description	5
Components List	6
Product Activation	7
Before Installation	8
X5 Installation	9
X5 All In One Installation	9
X5 Split Installation	10
X5 Plus Installation	11
X5 Plus All In One Installation	12
X5 Plus Split Installation	13
U-shaped Bracket Street Light Installation (Method 1)	14
U-shaped Bracket Street Light Installation (Method 2)	15
Clamping Bracket Street Light Installation	16
Troubleshooting	17
Indicating Descriptions	18

Before using the X5 & X5 Plus solar street light, carefully read the follow precautions to avoid damage or error.

Operation Conditions & Limits

- This product is rated as IP66 protection grade.
- The operating temperature range is from -20°C to 45°C and the charging temperature limit is within 0°C to 45°C.
- The heavy-duty structure will survive up to a Category 12 typhoon or cyclone. (Storms above Category 12 may cause damages to the product).

Transportation & Storage

- This product contains lithium batteries. Please follow air transport regulations when shipping. It should be regarded as potentially flammable and explosive, and be isolated from other goods when stored, so as to avoid any damage.
- The solar panels of this product should be considered as fragile. There should never be more than 4 layers of boxes when stacked. To avoid damage to the panels, make sure no heavy pressure is applied to the boxes.
- Please store the product in temperature between 0°C to 45°C.
- If stored for a long period, the product should be recharged every 6 months. Please only use the special charger (purchased from manufacturer) to avoid damage to the battery or device. The charging method is: first fully charge the battery power, then discharge the battery power, and finally charge to 50% power.

Product Recycling

- This product is made from recyclable, high-performance materials. All materials are compliant to the ROHS standard. Do not dispose of this product with other household waste.
- Please check your local regulations on collection and disposal of electronic items. Proper disposal of used product helps prevent negative impacts on the environment.

Product Maintenance

- To ensure effective solar radiation absorbing, clean the surface of the solar panels regularly with water and a soft cloth. Don't use highly soluble chemicals or abrasives containing aminobenzene.
- This solar street light operates on a low DC voltage. Unless it's customized, do not connect any components or ports to any AC power supply or higher rated DC voltage system.
- The light sources contained in these luminaries shall only be replaced by the manufacturer or his service agent or any equivalently qualified persons.
- Using any third party components to replace the original ones without authorization is forbidden. The product will lose warranty if the users disassemble the products without the manufacturer's prior authorization.
- To order replacement parts or to have them fitted, please visit www.pboxlighting.com or contact your local distributor.



Parts Description

Components List

X5 All-In-One

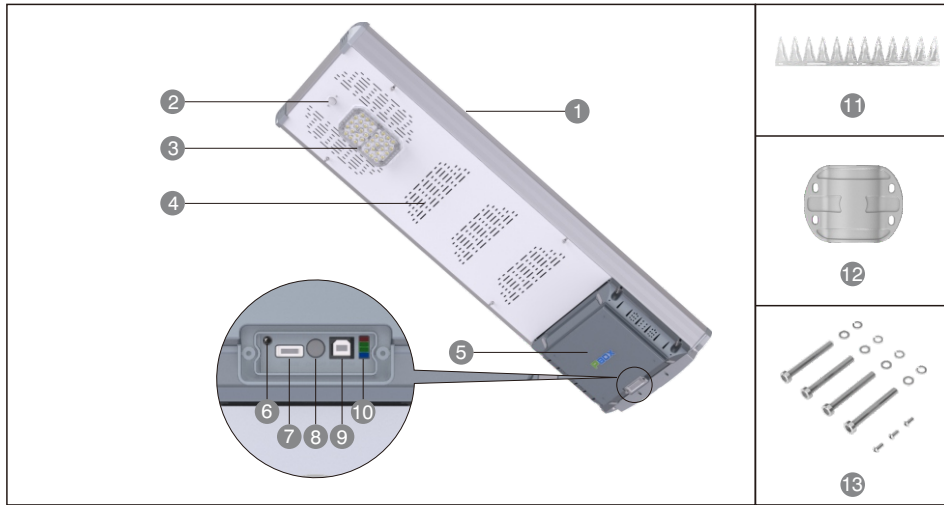

X5 Split Type

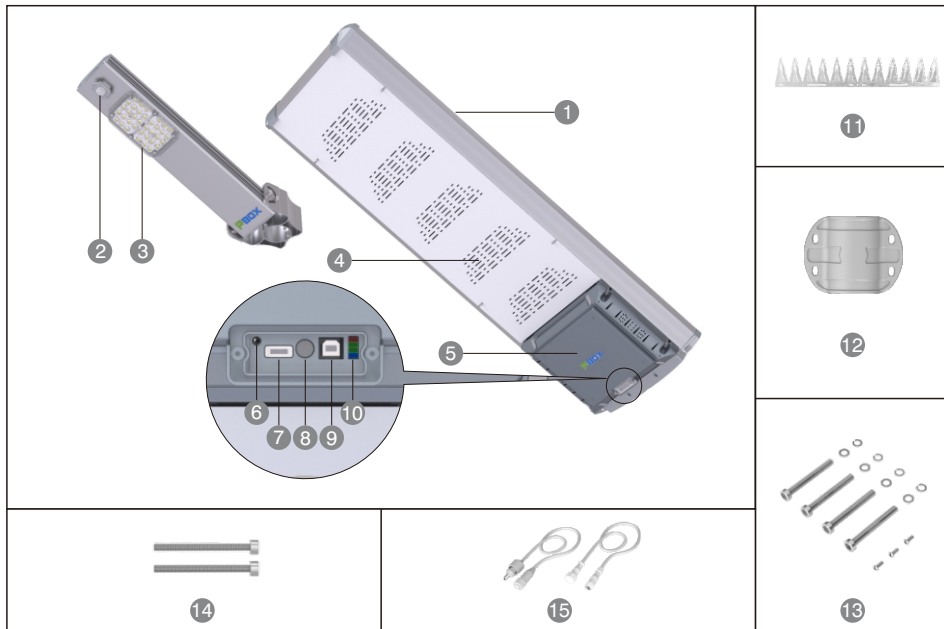

 Check if all the components are complete before installation, the components and quantity of each set as follows:

Product Manual

No.	Parts	Functions
1	Solar panel	Absorbs and converts solar energy into electricity
2	Motion sensor	Detects human movement
3	LED light	Lights the area
4	Vents	Heat dissipation
5	Control box	Battery (charge / discharge) management
6	Infrared remote control receiver	Infrared remote control
7	Type A USB port / Parameter Configuration Interface	For battery charging via a 14VDC 1.5A power supply / Parameter Configuration Interface
8	ON/OFF button	Turn on/off the light, or enter/exit the Transportation mode
9	Type B USB port	For program input
10	Function indicator lamps	To indicate the product's working status (See "Indicating Descriptions" on page 18 for more information.)
11	Bird spike	Prevents solar panel contamination from bird droppings
12	Bracket	To fix the solar engine
13	M8 hexagon headed screws 4pcs / M8 lock washers 4pcs / M8 flat washer 4pcs / self-tapping screw 3pcs	Fix the solar light and bird spike in place
14	M8×120 screws 2pcs	Fix LED street light
15	Waterproof extension cables	Connects the solar engine and LED lights

Parts Description

X5 Plus All-In-One

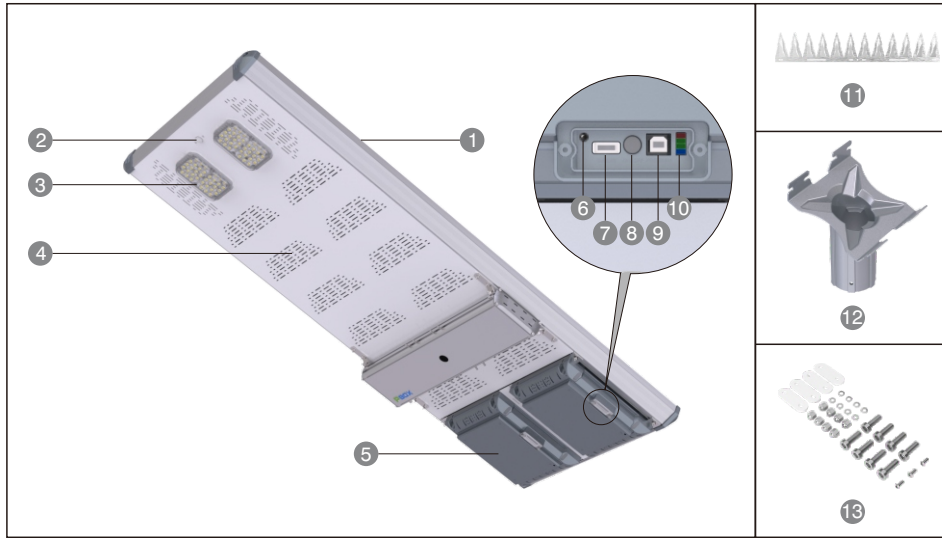

X5 Plus Split Type

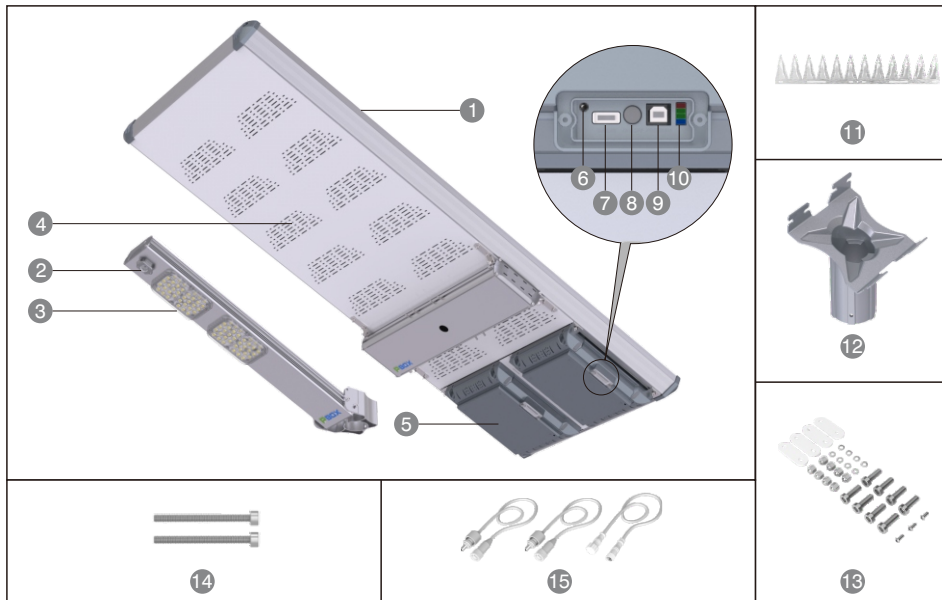

Components List

 Check if all the components are complete before installation, the components and quantity of each set as follows:

Split Type Street Light (Optional, with clamping bracket)

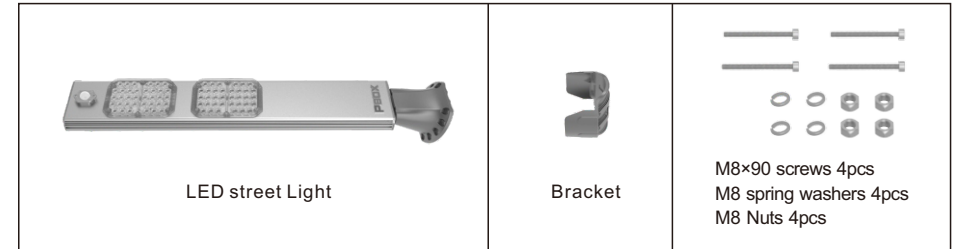

Product Manual

No.	Parts	Functions
1	Solar panel	Absorbs and converts solar energy into electricity
2	Motion sensor	Detects human movement
3	LED light	Lights the area
4	Vents	Heat dissipation
5	Control box	Battery (charge / discharge) management
6	Infrared remote control receiver	Infrared remote control
7	Type A USB port / Parameter Configuration Interface	For battery charging via a 14VDC 1.5A power supply/ Parameter Configuration Interface
8	ON/OFF button	Turn on/off the light, or enter/exit the Transportation mode
9	Type B USB port	For program input
10	Function indicator lamps	To indicate the product's working status (See "Indicating Descriptions" on page 18 for more information.)
11	Bird spike	Prevents solar panel contamination from bird droppings
12	X bracket	To fix the solar engine
13	Bracket buckles 4pcs / M6 cap nuts 8pcs / M6 spring washers 8pcs / M8x25 screws 8pcs / self-tapping screws 3pcs	Fix the solar light and bird spike in place
14	M8x120 screws 2pcs	Fix LED street light
15	Waterproof extension cables	Connects the solar engine and LED lights

- * **In the daytime:** When connecting the LED street light to the solar engine, the street light lights up for 20 seconds, and then turns off. It means the solar street light has been activated automatically.
- * **At night:** Press the ON/OFF button for 5 seconds, and then the LED street light switches on. It means the solar street light has been activated manually. Then, If you short press the button, the light will switch between ON and OFF.

*** Remarks:

* ON mode:

The system will work normally, charging in the daytime and discharging at night.

* Transport (idle) mode:

The solar street light will power off in one hour and then stay in the OFF mode, for transportation, storage, or maintenance purpose, until it's re-activated.

* OFF mode:

The system will not work, charge or discharge.

* Power ON:

a. In the daytime:

The solar street lights gets activated and powered on automatically (i.e. to light up for 20s and then switch off), once it is taken out of the carton (for the all in one type), or when the LED street light is connected to the solar engine (for the split type).

b. At night:

Long press the ON/OFF button for 5 seconds to get the solar street light activated manually (i.e. to switch on), with the solar engine connected to the led light.

* Power OFF:

Press the ON/OFF button for 5 seconds when the light is On, to see the light flashes for 3s and then switches off to come into Transport Mode; Then press the button for 5s again, or have no operation for one hour, to have the light flash for 1 second and switch off to get the solar street light power off.

* Switch on/off the light:

When the solar street light is activated and powered on, short press the ON/OFF button, and then the light will switch between on and off.

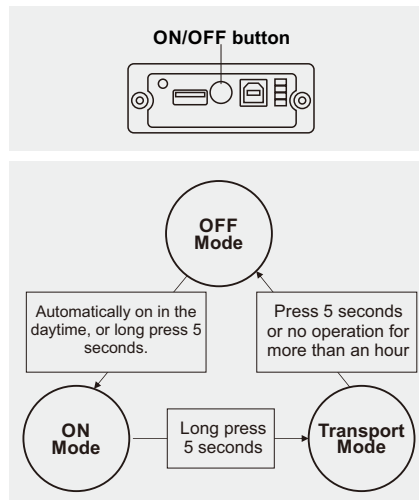

Working Mode Description

The product default setting controls the light through photo sensing of the solar panel. The light will turn on automatically when it's dark and turn off automatically when it's bright. At night it will go into the dim mode when no one is around and turn to full brightness when motion is detected.

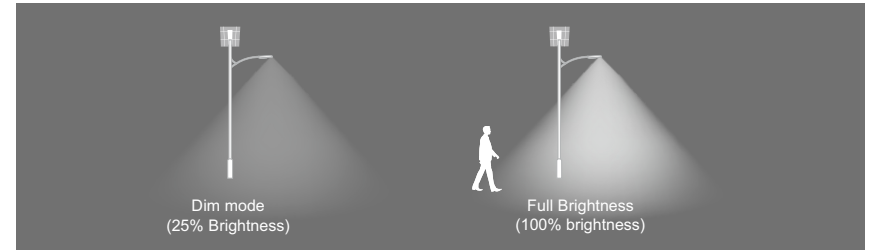

Installation Direction of Solar Panel

- Please select the appropriate product according to the installation site's sunlight intensity and required operating time. If you are in the northern hemisphere, face the solar panels towards the south as far as possible when installing the solar street light; if you are in the southern hemisphere, face the solar panels towards the north. (see picture 1)
- For maximum operation efficiency of the solar panels, make sure the sunlight is not blocked by buildings or trees. (see picture 2)

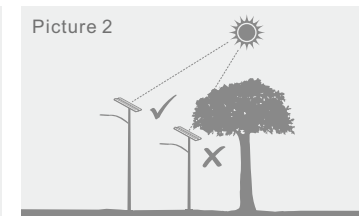
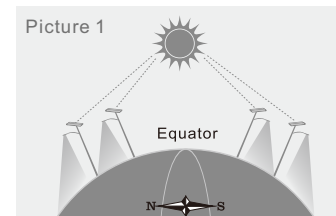

Installation Height and Distance

Before installing the solar street lights, please refer to the below recommended height and distance between two poles, based on the LED power of each product. Consult our product specialists for any special lighting requirements.

Power	Bat Wing Light Source	
	Installation Height	Installation Distance
15W	4~6m	15~25m
20W	4~6m	15~25m
30W	5~8m	20~30m
50W	7~10m	25~35m
80W	10~12m	30~40m

X5 Installation

Bird Spike Installation

Use 3 self-tapping screws to fix the bird spike along the rim of the top of the light. (See Figure 1)

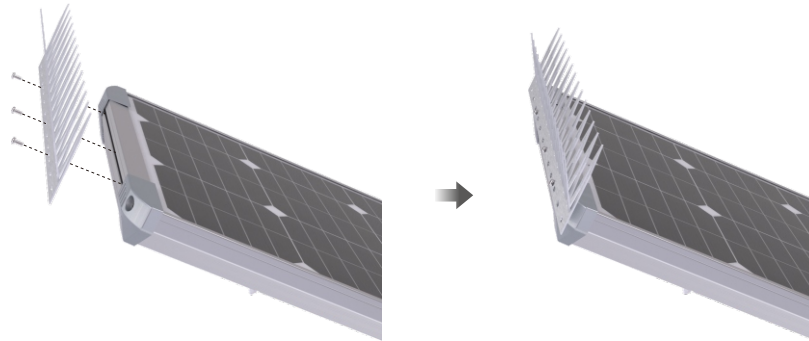

Figure 1

X5 Split Installation

- 1 Fit the solar engine and LED lamp position to suit sunlight and road conditions. Mark the position on the pole. In line with this mark, about 60mm from the top of the pole, cut a U-shaped hole with a width of 25mm for the cables to pass through. At approximately 600mm below the U-shaped hole, drill a circular hole $\text{Ø}25\text{mm}$ diameter, for the waterproof wires to pass through. (See Figure 3-1)

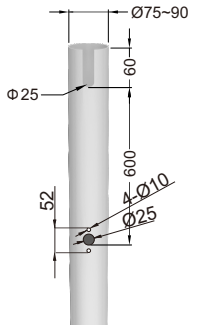

Figure 3-1

⚠ The product will be damaged if the top of the pole diameter is less than 75mm.

- 2 Push the waterproof cables through the 25mm diameter hole on the pole all the way through to the top of the pole.
- 3 **Install LED street light:** Connect the waterproof cables to the LED lights and ensure the plug fittings have been screwed down. Mount the LED light on the pole with 4pcs of M8 screws. The maximum torque for those M8 bolts is 14Nm. Do not surpass this torque specification. (See Figure 3-2)
- 4 **Install Solar engine:** First, attach the bracket to the solar engine, using M8 spring washers, flat washers and M8 screws to connect them, leave enough space to ensure the bracket can fit onto the pole. Connect the waterproof cables to the solar engine and ensure the plug fittings have been screwed down. Fit solar engine onto pole and make sure it is securely fastened. (See Figure 3-2)

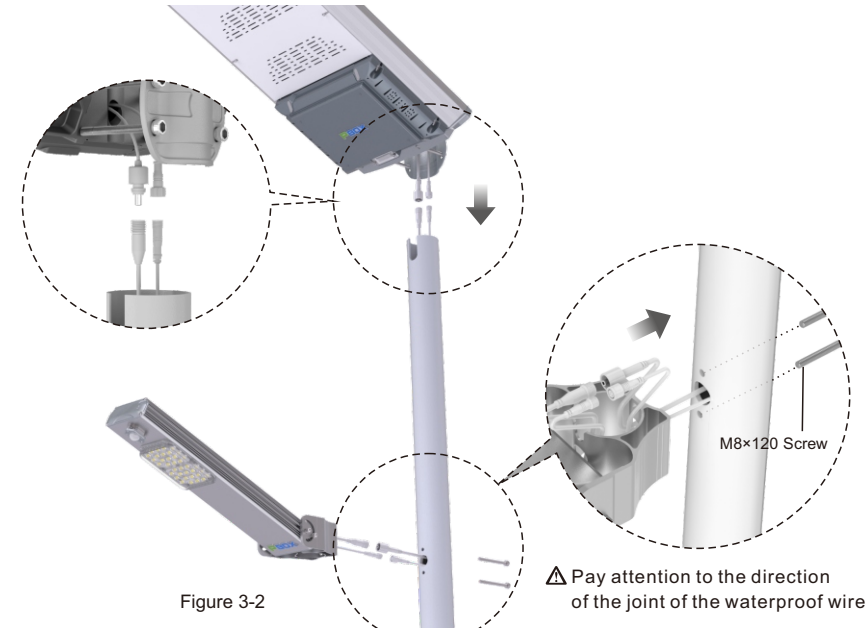
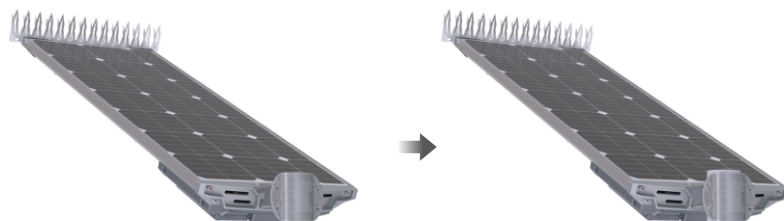

Figure 3-2

X5 All In One Installation

- 1 **Install bracket.** Use M8 spring washers, flat washers and M8 screws to connect them, leave enough space to ensure the bracket can fit onto the pole.
- 2 Fit solar light onto pole and make sure it is securely fastened with M8 screws. (See Figure 2). **The maximum torque for those M8 bolts is 14Nm.** Do not surpass this torque specification.



⚠ The product will be damaged if the top of the pole diameter is less than 75mm.

← → $\text{Ø}75\sim 90\text{mm}$

Figure 2

X5 Plus Installation

X Bracket and Bird Spike Installation

- 1 Fix the bracket to the bracket support with the 8 screws buckles, M6 spring washers, and M6 cap nuts. (See Figure 4)

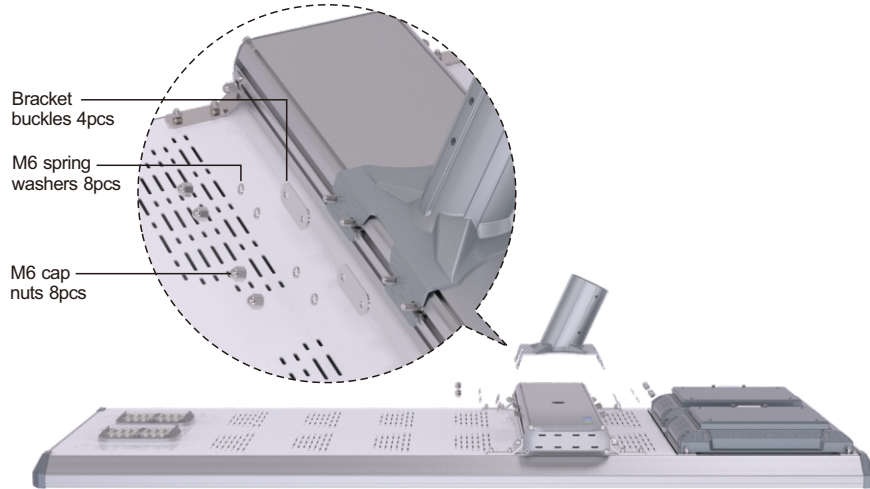

Figure 4

- 2 Use 3 self-tapping screws to fix the bird spike along the rim of the top of the light. (See Figure 5)

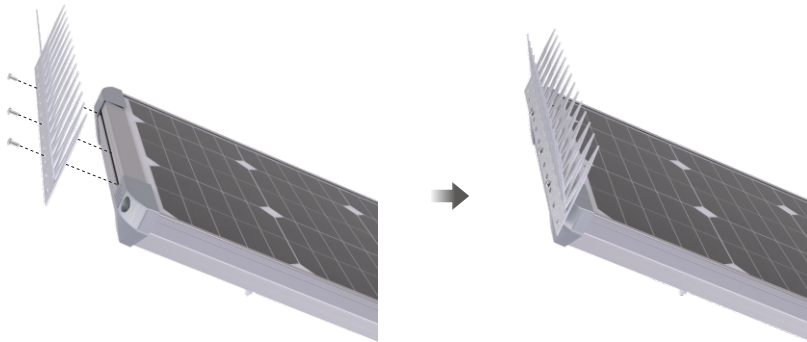

Figure 5

X5 Plus All In One Installation

- 1 At 65 mm from the top of the pole, drill a 10mm hole for fixing the X bracket. (See Figure 6)
- 2 Fix the light unit to the pole with M8×25 screws. The maximum torque for those M8×25 bolts is 14Nm. Do not surpass this torque specification. (See Figure 6)

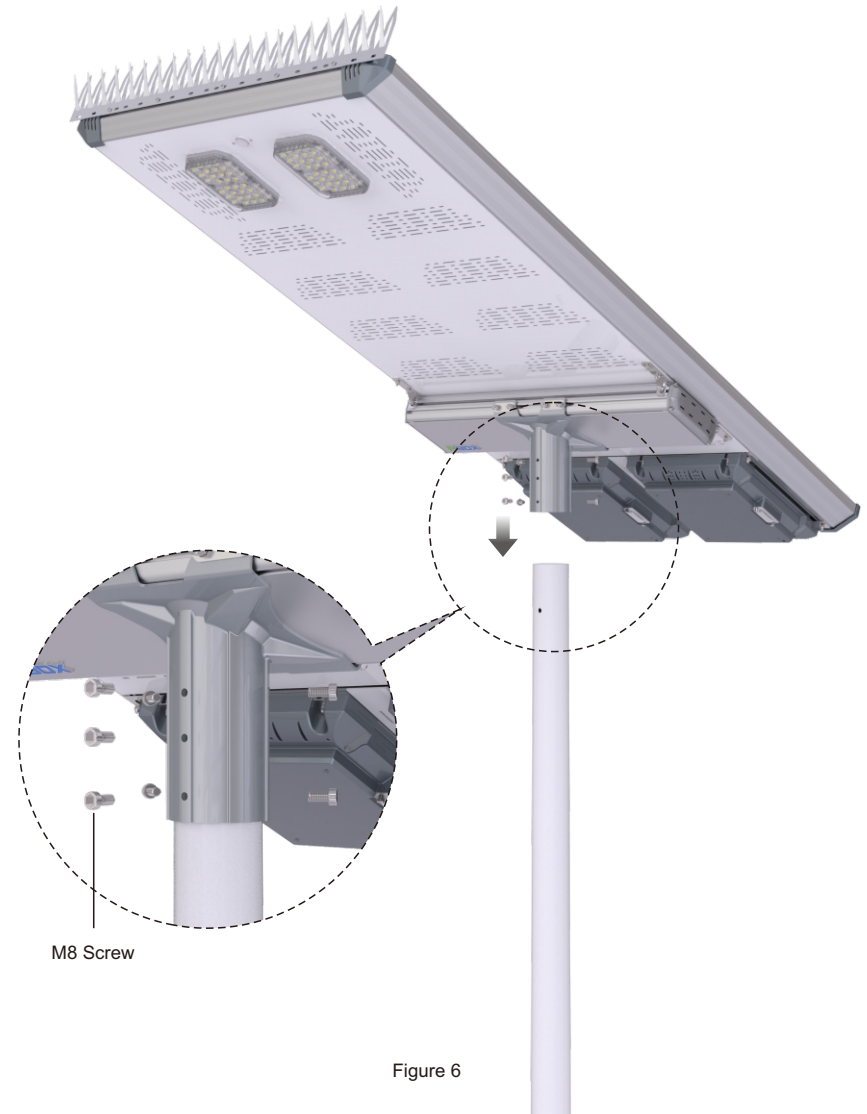
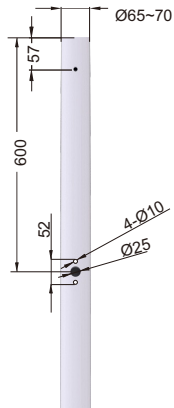

Figure 6

X5 Plus Split Type

Pole Requirements for LED street Light with U-shaped Bracket

- 1 If selecting straight pole for installation, 5 installation holes need to be opened in advance at about 600mm from the top of the pole according to Picture 7-1 shows.
- 2 It is advice that selecting a lamp arm to install for split type solar street light with U-shaped bracket. The diameter of the lamp arm can not beyond 60mm, as the Picture 7-2 shows.



Picture 7-1

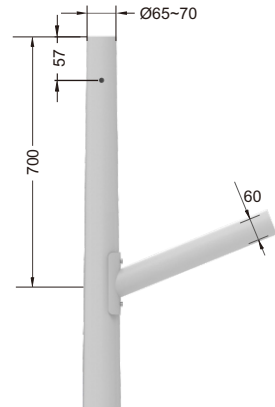

Picture 7-2

Pole Requirements for LED Street Light with Clamping Bracket

For split type street light with clamping bracket, open a round hole with a diameter of 25mm at the position 600mm from the top of the pole, as Picture 7-3 shows.

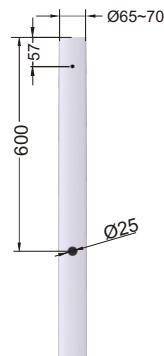

Picture 7-3

U-shaped Bracket Street Light Installation (Method 1)

- 1 Push the waterproof wires through the hole and the top of lamp pole. (See Figure 8-1)
- 2 **Install solar engine.** Connect the waterproof wires to the LED light wire and motion sensor wire, and screw down the connectors in turn. Insert the solar engine into the pole, and fasten it with M8 screws by wrench to ensure the stability of solar engine. Set the torque of electric wrench as 14N·m. (See Figure 8-2)
- 3 **Install LED street light.** Connect the waterproof wire to the LED street light and screw down the connectors in turn; Use the M8×120 screws through the hole on the pole, and screw down the U-shaped bracket of LED street light. Set the torque of electric wrench as 14N·m. (See Figure 8-2)

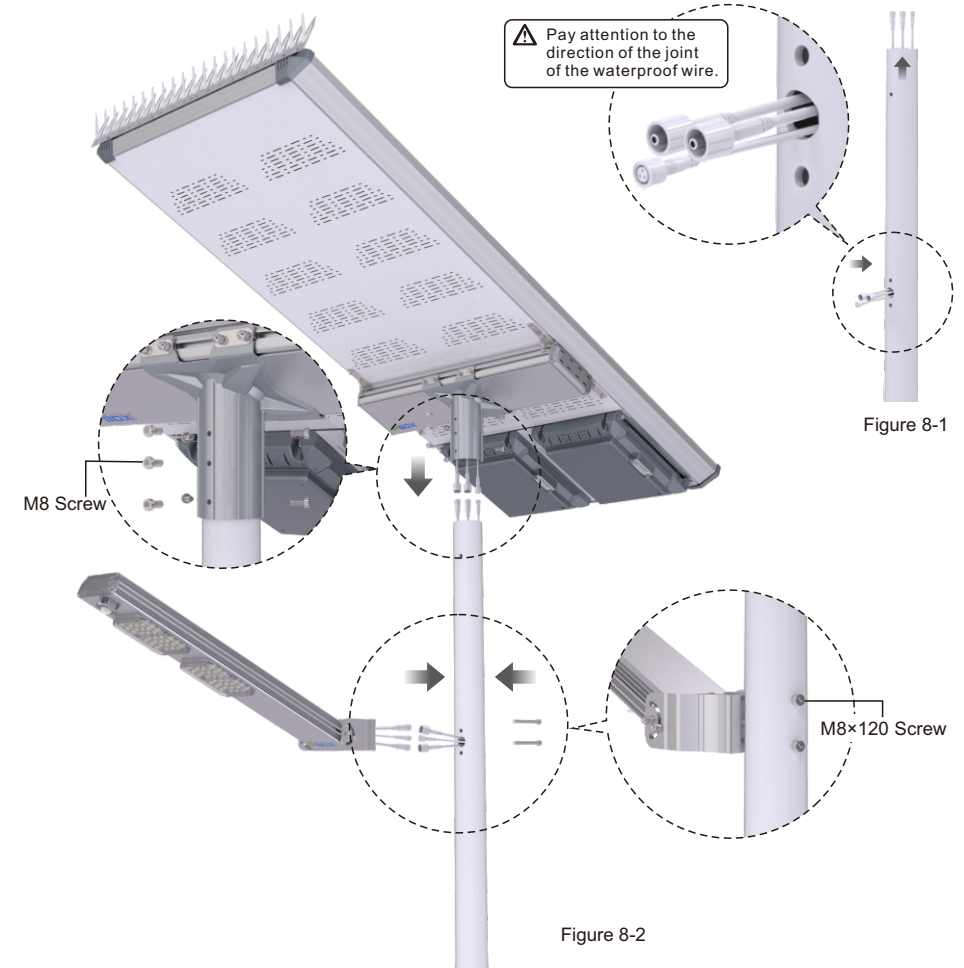

Figure 8-1

Figure 8-2

X5 Plus Split Type

U-shaped Bracket Street Light Installation (Method 2)

- 1 Push the waterproof wires through the lamp arm and the top of lamp pole. (See Figure 9-1)
- 2 **Install solar engine.** Connect the waterproof wires to the LED light wire and motion sensor wire, and screw down the connectors in turn. Insert the solar engine into the pole, and fasten it with M8 screws by wrench to ensure the stability of solar engine. Set the torque of electric wrench as 14N·m. (See Figure 9-2)
- 3 **Install LED street light.** Connect the waterproof wire to the LED street light and screw down the connectors in turn; Fit LED street light onto the lamp arm and fasten it with two M8 screws by using wrench. Set the torque of electric wrench as 14N·m. (See Figure 9-2)

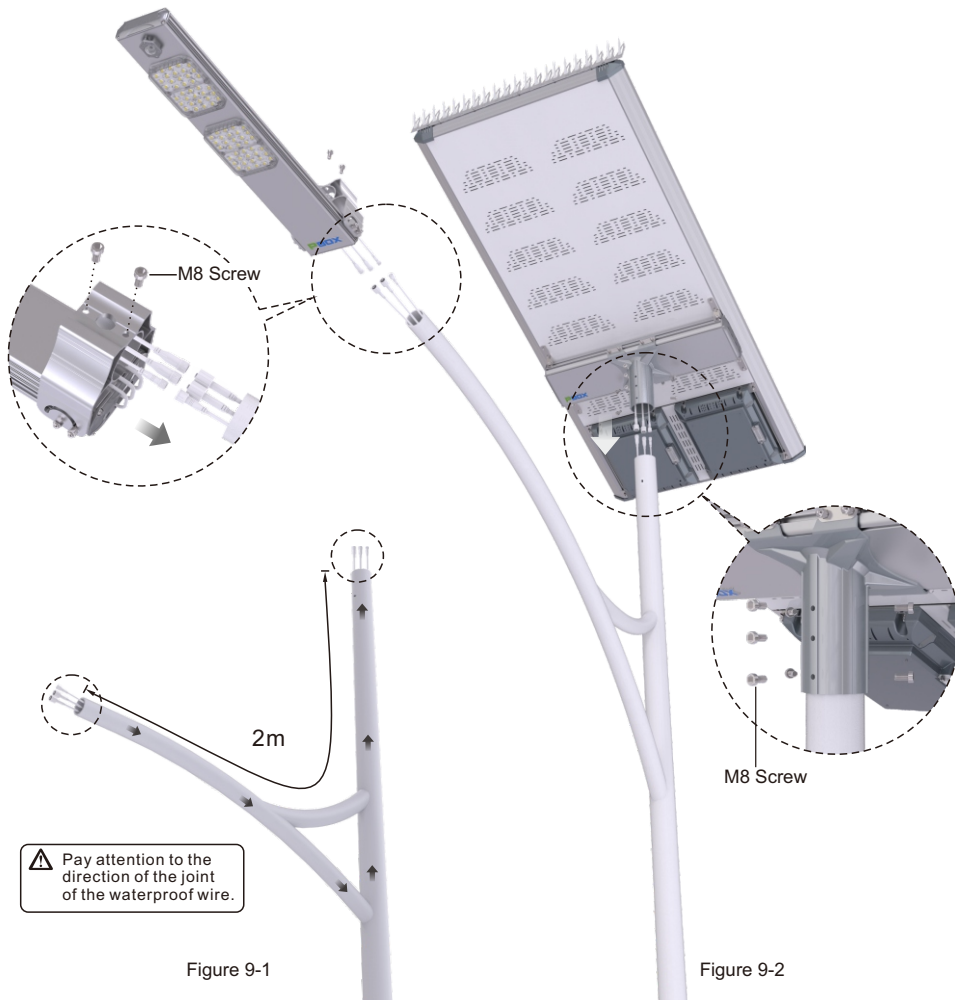

Figure 9-1

Figure 9-2

Clamping Bracket Street Light Installation

- 1 Push the waterproof wires through the hole and the top of lamp pole. (See Figure 10-1)
- 2 **Install solar engine.** Connect the waterproof wires to the LED light wire and motion sensor wire, and screw down the connectors in turn. Insert the solar engine into the pole, and fasten it with M8 screws by wrench to ensure the stability of solar engine. Set the torque of electric wrench as 14N·m. (See Figure 10-2)
- 3 **Install LED street light.** Connect the waterproof wire to the LED street light and screw down the connectors in turn; Screw down the lamp bracket and light hook by M8 spring pads, M8×90 screws and nuts to ensure the stability of LED street light on the pole. Set the torque of electric wrench as 14N·m. (See Figure 10-2)



Figure 10-1

Figure 10-2

Troubleshooting

No.	Symptoms	Troubleshooting Steps	Process
1	No light at night	Check that the lamp can be manually activated.	Refer to "Activation and Installation" section on this user guide and run activation tests.
		Check if the solar panel is blocked from the sunlight by houses, trees and other obstacles.	Clear obstructions or change installation location.
		Check if there is any artificial light source(s) shining on the solar panel during the night.	Remove the artificial light source(s) of interference or change the installation location.
		Examine status of each component based on the repair guide.	Replace the damaged component(s).
2	A serious shortage of working time at night	Check if the solar panel is blocked from the sunlight by houses, trees and other obstacles.	Clear obstructions or change installation location.
		Check if the surface of the solar panel is dusty or covered.	Clean the surface of solar panels as detailed above.
		Examine if the battery pack is damaged as per the repair guide instructions.	Replace damaged battery.
3	Lighting does not follow the normal operation mode of turning on and off		Replace controller(s) and reprogram.
4	Abnormal motion sensor	Check if the air temperature is close to human body temperature.	When the air temperature is close to human temperature, motion detection may slow down. It will return to normal after the air temperature changes.
		Check if the installation height is too high.	It is out of motion detection range when installation height exceeds 8m. It is recommended to reduce the height or use other operating modes.
		Check if the motion sensor or controller(s) is damaged.	Replace damaged motion sensor or controller(s).

Indicating Descriptions

No.	Indicator Lamps' Working Status	Product Function Descriptions
1	Blue lamp slowly flashing, red lamp instantly flashing.	Battery cannot get recharged.
2	Blue lamp constantly on, red lamp instantly flashing.	Battery cannot get discharged.
3	Blue lamp instantly flashing, red lamp off.	Battery over-discharged.
4	Blue lamp constantly on, red lamp quickly flashing.	DCOUT short-circuited.
5	Blue lamp slowly flashing, red lamp quickly flashing.	LED lamp short-circuited.
6	Blue lamp constantly on, red lamp constantly on.	LED lamp has no power supply.
7	Blue lamp instantly flashing, red lamp constantly on.	No voltage increase to the led lamp.
8	Blue lamp quickly flashing, red lamp constantly on.	LED lamp open-circuited.
9	Blue lamp slowly flashing, red lamp constantly on.	Abnormal Voltage of LED lamp.
10	Blue lamp constantly on, red lamp off.	Normal discharging
11	Blue lamp off, red lamp off, green lamps off.	No indication
12	Both green lamps 1 and 2 slowly flashing.	Battery recharging
13	Both green lamps 1 and 2 constantly on.	Battery fully recharged.
14	Both green lamps 1 and 2 quickly flashing.	Charging exceeds protection current.
15	Both green lamps 1 and 2 quickly flashing, red lamp quickly flashing.	Charging exceeds inhibit current (short circuit)

⚠ Remarks:

1. Annotations:

Slowly flashing: The indicator lamp turns on, and then turns off in 640ms, then turns on again in another 640ms, then turns off again in another 640ms,

Instantly flashing: The indicator lamp turns on, and then turns off in 80ms, then turns on again in another 1.2s, then turns off again in another 80ms, then turns on again in another 1.2s,

Quickly flashing: The indicator lamp turns on, and then turns off in 80ms, then turns on again in another 80ms, then turns off again in another 80ms,

2. In case you have any difficulty to determine the indicator lamps' working status, please just take a short video of the indicator lamps' working and send it to our factory for further analysis.